



MANUAL MONARK MEDICAL TREADMILL

THANK YOU FOR CHOOSING A PRODUCT FROM MONARK EXERCISE!

Monark Exercise develop, manufacture and market cycle ergometers, treadmills and exercise bikes for hospitals, health care facilities, sports medicine institutions and research laboratories. Since the early 1900s, Monark Exercise products have been living proof of precision, reliability, durability, strength and service. We are therefore a world leader in medical training and test equipment and our products are retailed in more than 70 countries worldwide.

For more information, please visit www.sport-medical.monarkexercise.se



FACTS	4
MONARK MEDICAL TREADMILL	
Dimensions	
Pulse Registration	
OPERATING INSTRUCTION	5
START THE TREADMILL	
Resetting distance and time	
Incline Function	
Stop the Treadmill	
Emergency Stop	
Safety Cord	
MONARK NOVO CONTROL UNIT	6
Connect external device via RS232 and USB	
MONARK NOVO DISPLAY UNIT	7
Menu	
Pulse Settings	
IF YOU USE CHEST BELT	8
Disturbances of pulse measurement	
REGULAR MAINTENANCE	9
Checking the tension of the motor belt	
OTHER SERVICE / REPAIRS	9
WARRANTY	9
SERVICE ACTIONS	10
Remove Handle Bars	11
Remove Panel and Monark novo Display Unit	12
Remove Monark novo Control Unit	13
Remove Cover	13
Open Electronic Box	14
Remove Incline Motor	19
Remove Rollers, Belt and Board	20
Remove Castors	22
Adjustable Rear Support Feet	22

IMPORTANT

Before using your new treadmill, please read the manual carefully and save it for future use.

SERIAL NUMBER

XXX XXX XXX

DIMENSIONS

Total length: 250 cm
Total width: 84.5 cm
Weight: 230 kg
Total height: 136 cm
at Display Unit

RUNNING SURFACE

Height to : 17 cm
Length: 158 cm
Width: 52 cm

Max user weight: 250 kg

THE DISPLAY SHOWS

- Current speed in km/h
- Treadmill incline in degrees
- Distance in km
- Time in minutes and seconds
- Pulse (if chest belt is used)

NOTE!

Use of the product may involve considerable physical stress. It is therefore recommended that people who are not accustomed to cardiovascular exercise or who do not feel completely healthy, should consult a physician for advice



FACTS

Monark Medical Treadmill is a Medical device according to Medical Device Directive, MDD 93/42/EEC class IIa.

The treadmill is available in two variants - with or without pulse function.

MONARK MEDICAL TREADMILL

The Monark Exercise Medical Treadmill is an exercise device for walking or running and is primarily developed to be used in a medical environment. The possibility to change and control the speed and inclination of the moving belt which allows the device to be used for training, diagnostics and therapy applications. As the moving belt can be controlled at very low speeds, the Monark Exercise Medical Treadmill is extra suitable for patients who undergo different rehabilitation programs where low speeds are important.

The physical condition of patients can be analysed by through different treadmill stress test protocols, also in combination with a metabolic cart. The Monark Exercise Medical Treadmill is designed for both manual operation and to be controlled via external devices and can then be used as a loading device for ergospirometry, ECG measurements and different stress tests for cardiovascular diseases.

The Monark Exercise Medical Treadmill should be operated by well-trained specialist staff only. The correct loading for a patient on the treadmill must be prescribed and monitored by a medical doctor and/or well-trained medical specialists.

PULSE REGISTRATION - If you have pulse function in your treadmill

The treadmill has a module that registers the heart rate data from chest belts, or similar, with ANT+ or Bluetooth SMART profile.

We recommend to use a Bluetooth SMART device, e.g. Polar H7, as this allows the treadmill to pair with the heart rate sensor, which ensures a more stable connection.

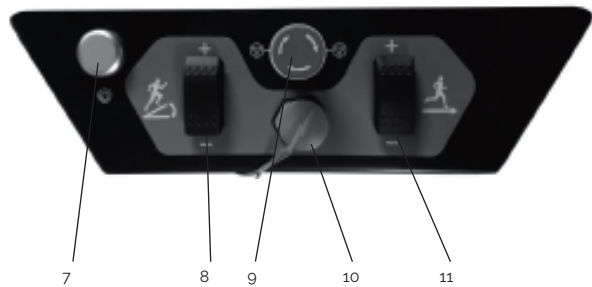

FIG: CONTROL PANEL

- 7) On / off button
- 8) Incline +/-
- 9) Emergency stop
- 10) Safety cord
- 11) Speed +/-

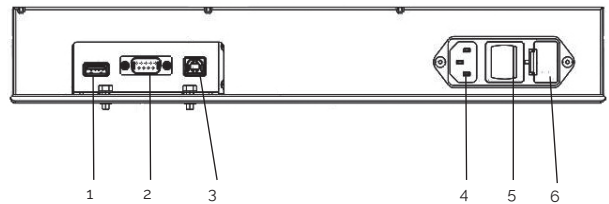

FIG: FRONT CONNECTIONS

- 1) Connection USB type A (only charging of e.g. smartphone, etc.)
- 2) Connection RS232
- 3) Connection USB type B
- 4) Power connection
- 5) On / off button
- 6) Fuse

OPERATING INSTRUCTION

START THE TREADMILL

Connect the power cable and press the on / off button (5) next to the power connector (4), see fig: Front connections.

Now the treadmill is ready for use.

Press the green on / off button (7) on the control panel and the band starts at a speed of 0.1 km / h.

To increase the speed, press up on speed button (11) (towards +). For each pressing, the speed increases at 0.1 km/h. Holding down the button will increase the speed by 1.0 km / h.

To decrease the speed, press down on speed button (11) (towards -) instead and then the speed decreases with the same values, 0.1 resp. 1.0 km / h).

RESETTING DISTANCE AND TIME

The displayed values for distance and time will not be reset when starting the belt after it has been stopped. To reset the distance and time values, hold down the on/off button (7) for three seconds. The distance and time will start from zero when starting the belt next time.

INCLINE FUNCTION

If you want more resistance, you can raise the front of the treadmill. To do this, press the incline button (8) up (towards +) on the control panel. For each push the inclination is increased by 0.5°. If you want to decrease the incline, press down (towards -) on the button.

If the treadmill is inclined when switched off (button 7) or unplugged, it needs to manually be lowered to its lowest position, in order reset the inclination value. The incline value on the display will show 0, until this procedure has been performed.

For everyday use, we recommend leaving the treadmill switched on during the day and manually lowering it to 0° before switching it off.

STOP THE TREADMILL

To stop the treadmill, press the green on / off button (7). The belt will brake smoothly before coming to a complete stop.

EMERGENCY STOP

The treadmill is equipped with an emergency stop (9), see Fig: Control panel, to use in case of injury or accident, or if you, for any reason, must stop the band quickly. If you press the emergency stop, the band stops abruptly.

If you used the emergency stop, turn the button to the right, according to the arrows, and press the on / off button (7) once to reset the function.

SAFETY CORD

We recommend using the safety cord (10), see fig: Control panel. Should you stumble and fall, it works in the same way as the emergency stop, the treadmill stops abruptly.

After using the safety cord, you must put the magnet (10) back in its place and then press the on / off button (7) once to reset the emergency stop. Press the on / off button (7) once more to restart the treadmill.

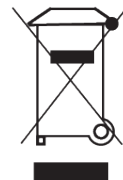

NOTE!

It does not work to connect the PC to the treadmill. Only ECG or spirometry can be connected to control the treadmill.

A medical electrical system (ME-System) is created when the treadmill is combined with an external device. The responsibility rests with the manufacturer of this ME-System and not with Monark Exercise.

MONARK NOVO CONTROL UNIT

Connect external device via RS232 and USB

We recommend that you set the treadmill power switch to “off” when connecting external devices to avoid the transmission of incorrect data.

Be careful when connecting different types of external devices to prevent flash-over and subsequent injury. The user must be certain that the instrument connector and the cable are designed for the intended purpose. Serious injury to the user and / or device may result if inappropriate connections are attempted.

Both RS232 port and USB-B port are located on Monark novo Control Unit in the front of the treadmill, see fig: Front connections.

First connect to the Monark novo Control Unit and then to the external device. Set the treadmill power switch to “on” and then start the external device.

MONARK NOVO DISPLAY UNIT

MENU

In the display is a menu where you can change different settings. You can find it by pressing the Menu icon. Then a menu is showed to the right in the display where you can select the following:



Pulse settings - **If you have pulse function in your treadmill**
(Pulse settings)



General settings
(Settings)
Not activated

You can at any time during the training open the menu to e.g. search for a chest belt.



PULSE SETTINGS - If you have pulse function in your treadmill

Here you can choose what heart rate standard you want the treadmill to search for, Bluetooth SMART, ANT+ or both.

The person's heart rate ("pulse") can be measured by, for example, a chest belt that detects your pulse from your heart and sends the pulse to the treadmill with Bluetooth SMART or ANT+ technology.

Bluetooth SMART

When the treadmill and a Bluetooth SMART heart rate monitor have been paired the heart rate monitor Bluetooth ID and the current heart rate is displayed at "Pulse". You can choose to actively lock the heart rate monitor by pressing "Lock". Then the treadmill is only searching for that particular heart rate monitor. Press "Reset" if you want to release the lock to only a specific heart rate monitor and lock with a new or continue to search freely.

You can use several Bluetooth SMART heart rate monitors to the treadmill, but you can only lock to one at a time.

The treadmill locks to the heart rate monitor that it finds first (within 10 m). If more heart rate monitors are used, we therefore recommended to lock into a specific Bluetooth ID to ensure that the correct heart rate appears.

ANT+ (ANT+ is always active)

ANT+ uses "proximity pairing" which means that you should be close to the display for it to start listening to it. When the display and the heart rate monitor is paired, you can be relatively far from the bike with retained function. This process ensures that the display is listening on the correct belt.

If you have connected to an ANT+ heart rate monitor it says "connected" at "ANT+ status:" and the current heart rate is displayed at "Pulse".

THE DISPLAY SHOWS

- Current speed in km/h
- Treadmill incline in degrees
- Distance in km
- Time in minutes and seconds
- Pulse (if chest belt is used)

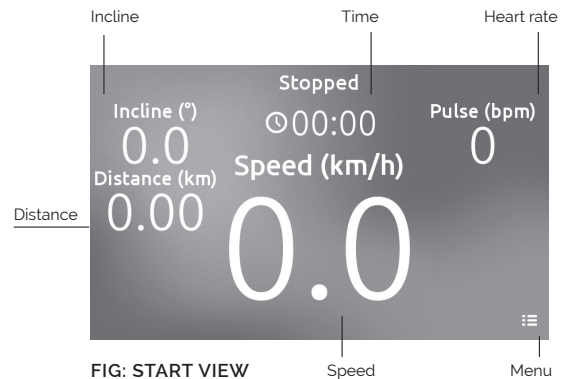

FIG: START VIEW

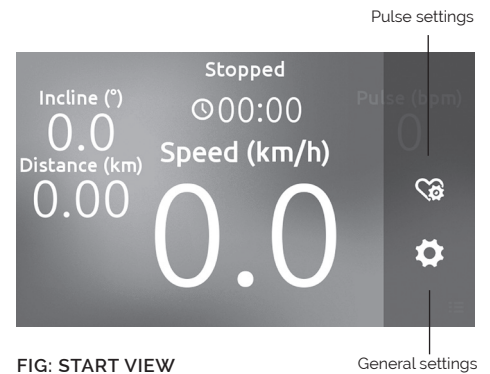
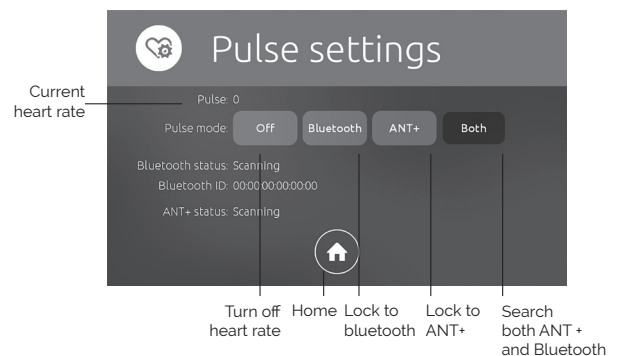

FIG: START VIEW





IF YOU USE CHEST BELT

- If you have pulse function in your treadmill

Heart rate registration requires that the heart rate monitor is positioned correctly. When it is correctly fitted the logo on the belt will be central and readable, outward and upright, by another person. Before putting on the belt, clean the skin where the belt is to be placed. The chest belt should be secured at a comfortable tension around the mid section, just below the breast muscle, see Fig: Placement chest belt. Moisten the electrodes before use, see Fig: Moistening the electrodes.

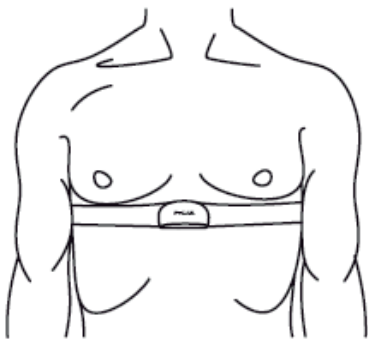

FIG. PLACEMENT CHEST BELT

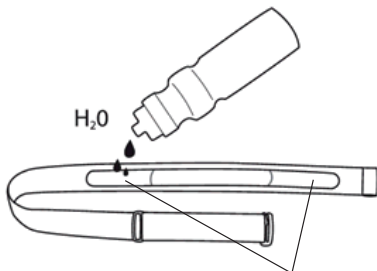

FIG. MOISTENING THE ELECTRODES

Disturbances of pulse measurement

If you experience disturbances in heart rate measurement use an external device (e.g. pulse clock) to check if it also shows irregular pulse. If so, it may be due to interference in the room. The disturbance may come from electric fields from power cords, elevators, lamps, etc. or other electronic devices which are too close (e.g. mobile phones). If possible, move the treadmill to another room or change room. Even synthetic fabrics can create static electricity that interferes with heart rate signal.

If the pulse remains irregular at work the person's health should be examined.

REGULAR MAINTENANCE

In order to keep your treadmill in good condition, it should be maintained and serviced regularly.

- Use the vacuum cleaner under the treadmill at least once a week, and in the engine compartment once a month.
- Wipe off sweat with mild soap solution and soft damp cloth. Do not spray detergents directly on the display or console as too much liquid may penetrate and destroy the function.
- If necessary, the treadmill can be surface disinfected. Then use an isopropanol-based preparation. Use a damp, not wet, cloth or sponge to wipe off the surfaces you want to disinfect.
- Metal surfaces can be surface-treated with a rust-proof, especially after they are cleaned and the surfaces dry.
- Check that the running belt is centered and does not slip on the rollers. If the belt slips or moves to one side, it needs to be adjusted. This is done by adjusting the two M10 screws at the rear roller, see fig: Adjusting the running belt.

Checking the tension of the motor belt

Check the tension of the motor belt twice a year and/or if the motor belt slip or sounds unusual. Switch off the treadmill with the on/off button at the front of the treadmill and unplug the power cable from the socket. Remove the cover. Inspect the motor belt visually for abrasion and correct fitting. Try to rotate the motor belt 90° sideways, only by using your thumb and forefinger and with moderate force. If you can rotate the motor belt more or less than 90°, the tension is too low or too high and needs to be adjusted. Use the screws for the motor belt tensioner to adjust the tension.

NOTE!

Always disconnect power by disconnecting power cord before performing any service point!

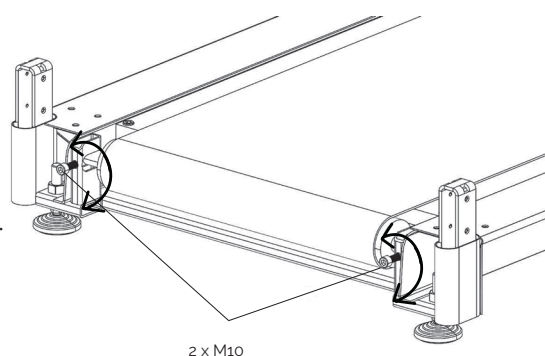

FIG: ADJUSTING THE RUNNING BELT

OTHER SERVICE / REPAIRS

If you require service or major repairs, we recommend that you contact your dealer or our service department.

WARRANTY

EU countries - Private use

If you are a consumer living in the EU you will have a minimum level of protection against defects in accordance with EC Directive 1999/44/EC. In short, the directive states that your Monark dealer will be liable for any defects, which existed at the time of delivery. In case of defects, you will be entitled to have the defect remedied within a reasonable time, free of charge, by repair or replacement.

EU countries - Professional use

Monark Exercise products and parts are guaranteed against defects in materials and workmanship for a period of one year from the initial date of purchase of the unit. In the event of a defect in material or workmanship during that period, Monark Exercise will repair or replace the product. Monark Exercise will not, however, refund costs for labour or shipping.

Other countries

Monark Exercise products and parts are guaranteed against defects in materials and workmanship for a period of one year from the initial date of purchase of the unit. In the event of a defect in material or workmanship during that period above, Monark Exercise will repair or replace (at its option) the product. Monark Exercise will not, however, refund costs for labour or shipping.

SERVICE ACTIONS

REMOVE HANDLE BARS

1. Remove cover, see section "Remove cover"
2. Disconnect handle bar cable from main frame
3. Remove 12 M8 screws, see fig: 2
4. Remove 16 M8 screws, see fig: 3
5. Lift up and remove handle bars, see fig: 4.

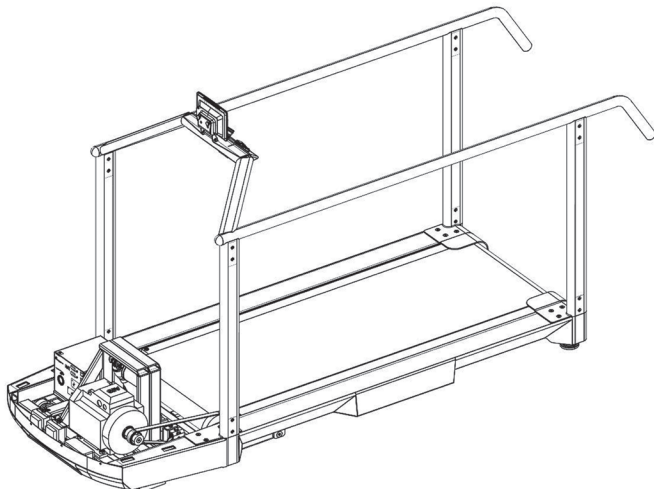

FIGURE 1

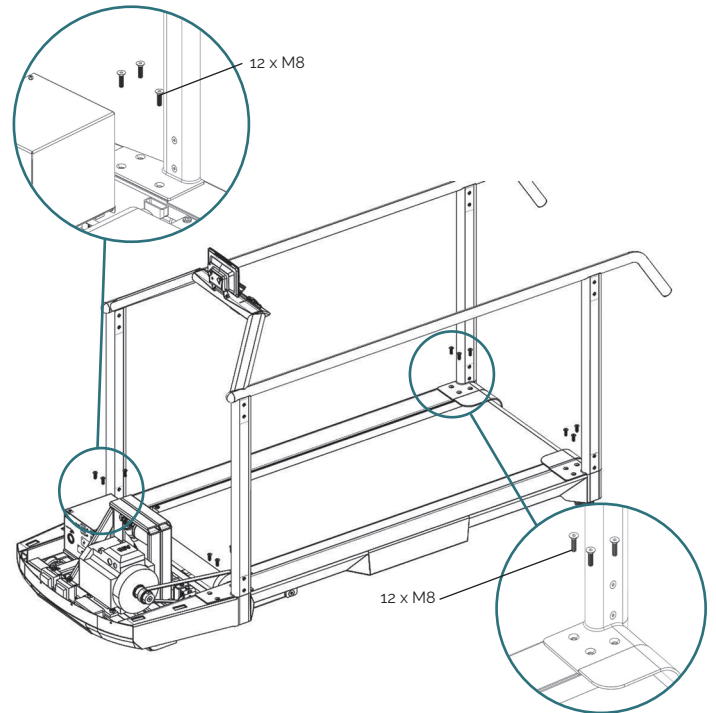

FIGURE 2

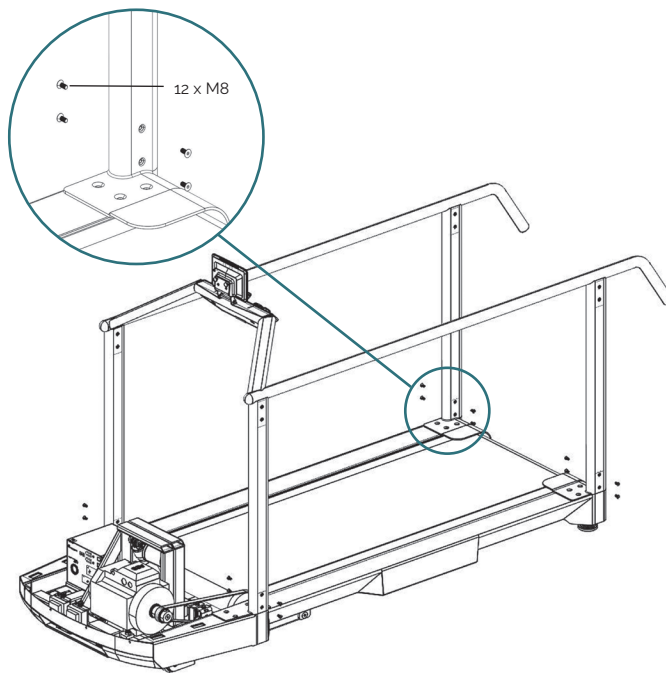

FIGURE 3

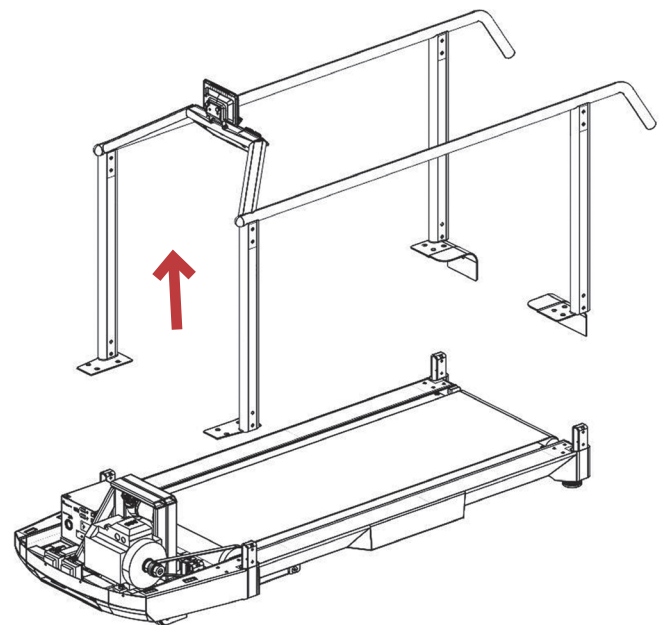

FIGURE 4

REMOVE PANEL WITH MONARK NOVO DISPLAY UNIT

1. Remove two M4 screws, see fig: 1
2. Open protective cover as shown in fig: 2
3. Disconnect main cable
4. Remove two M4 screws, see fig: 3
5. Remove panel with Monark novo Display Unit, see fig: 4

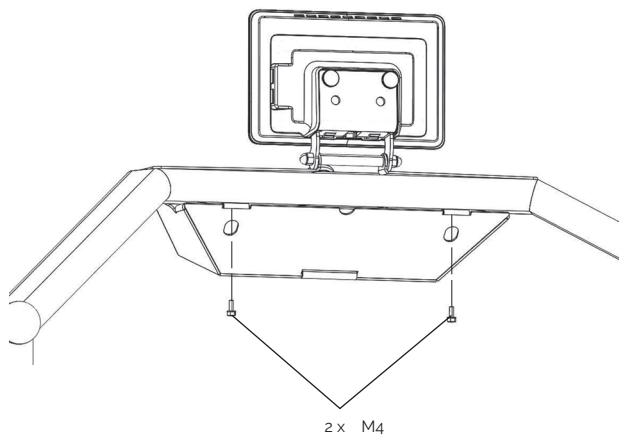

FIGURE 1

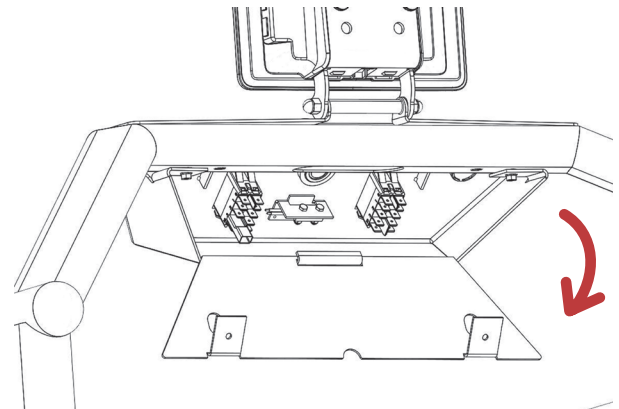

FIGURE 2

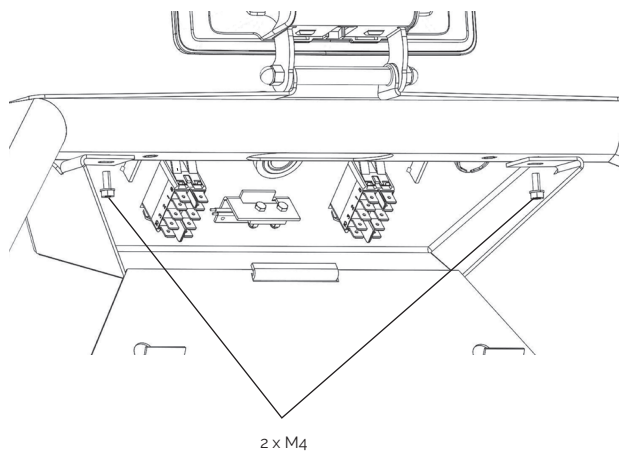

FIGURE 3

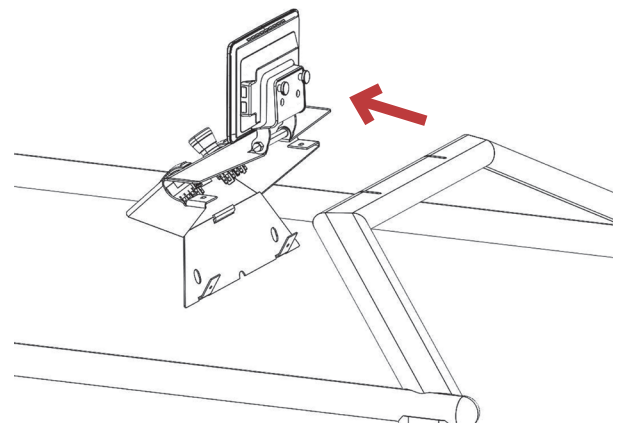

FIGURE 4

REMOVE MONARK NOVO DISPLAY UNIT

1. Remove two M8 nuts and washers, see fig: 5
2. Remove threaded shaft, see fig: 6
3. Remove Monark novo Display Unit bracket (turn the screws counterclockwise) and disconnect Monark novo Display Unit, see fig: 7

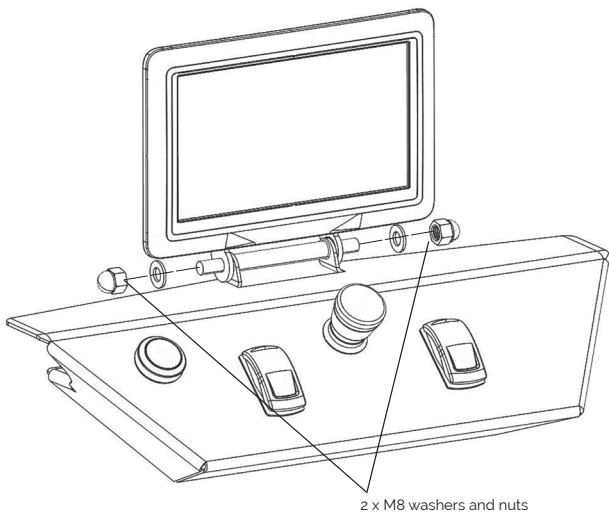

FIGURE 5

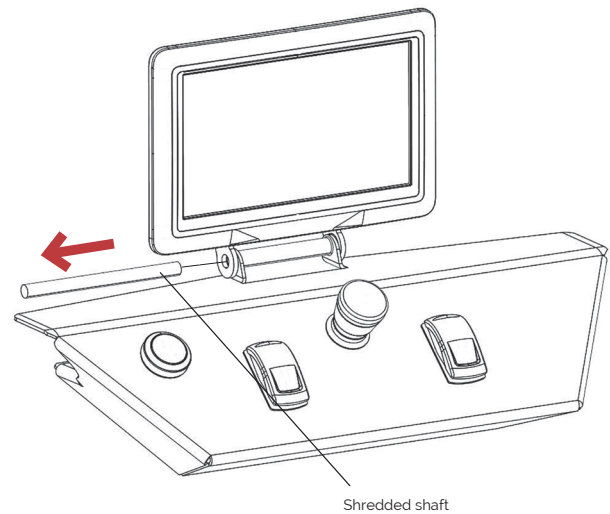

FIGURE 6

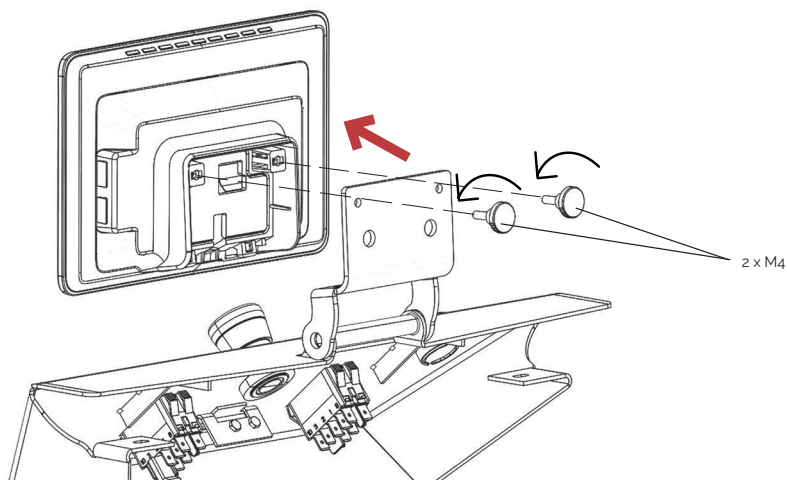

FIGURE 7

REMOVE PANEL WITH MONARK NOVO CONTROL UNIT

1. Remove cover, see section "Remove cover"
2. Disconnect all cables from Control Unit
3. Remove two M4 screws and nuts from outside, see fig: 1
4. Remove two M4 screws and nuts from inside, see fig: 2
5. Rotate and remove Control Unit, see fig: 3

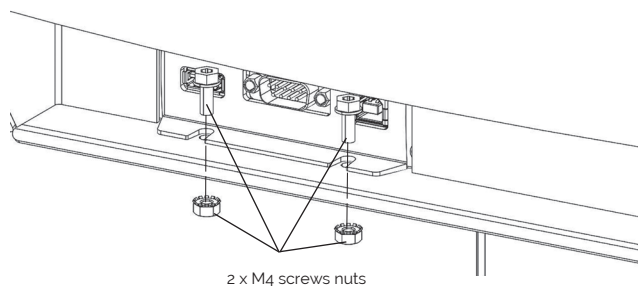

FIGURE 1

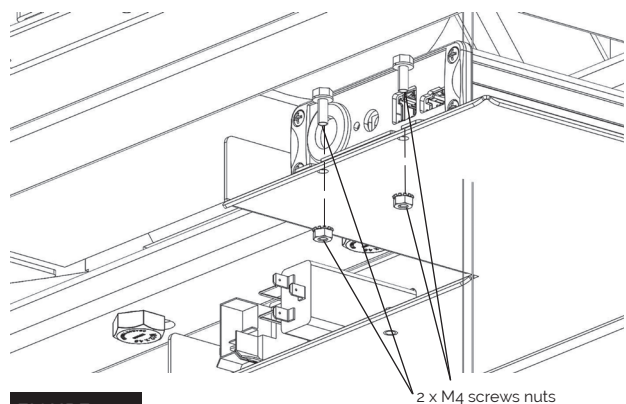

FIGURE 2

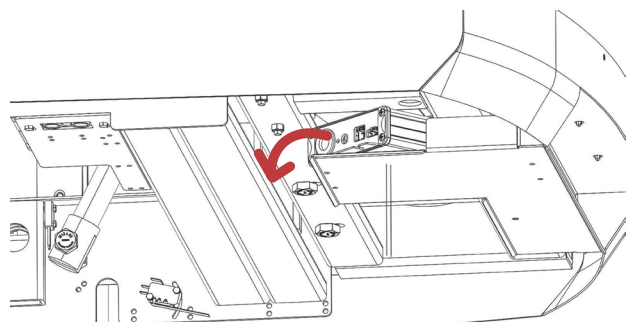

FIGURE 3

REMOVE COVER

1. Remove four M4 screws, see fig: 1
2. Carefully slide cover to front side, see fig: 2
3. Lift up cover, see fig: 3

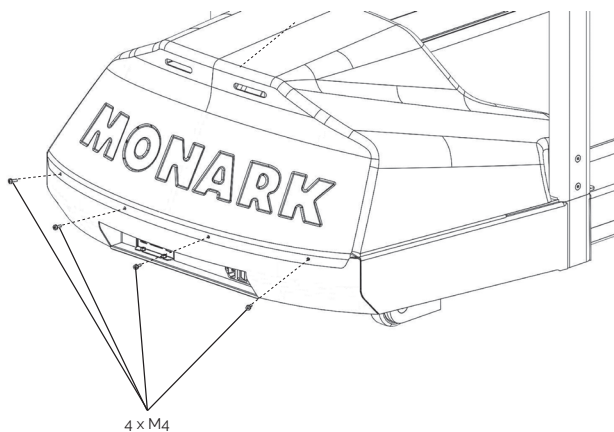

FIGURE 1

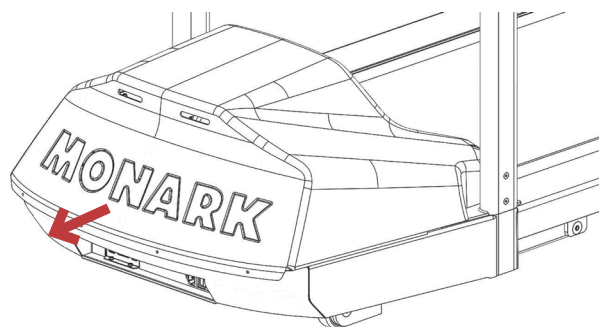

FIGURE 2

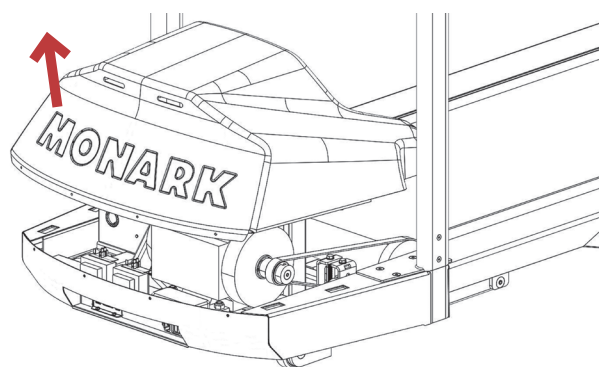

FIGURE 3

OPEN ELECTRONIC BOX

1. Remove cover, see section "Remove cover"
2. Remove two M4 screws, see fig: 1
3. Tilt cover as shown in image, see fig: 2 and fig: 3
4. Remove electronic box cover

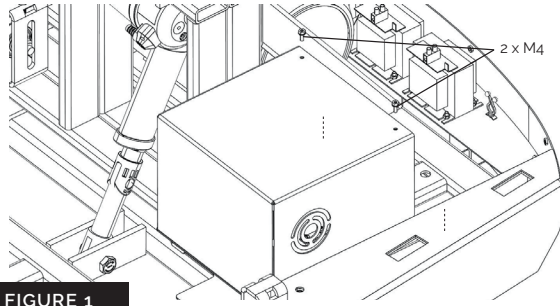

FIGURE 1

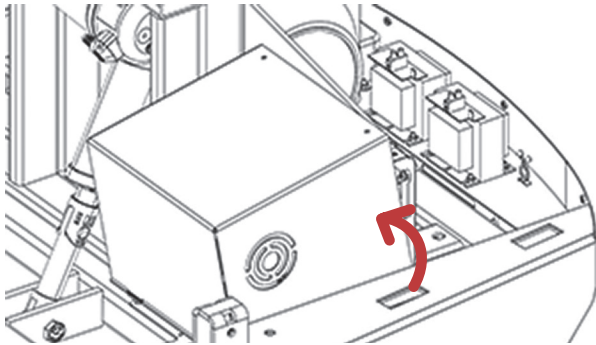

FIGURE: 2

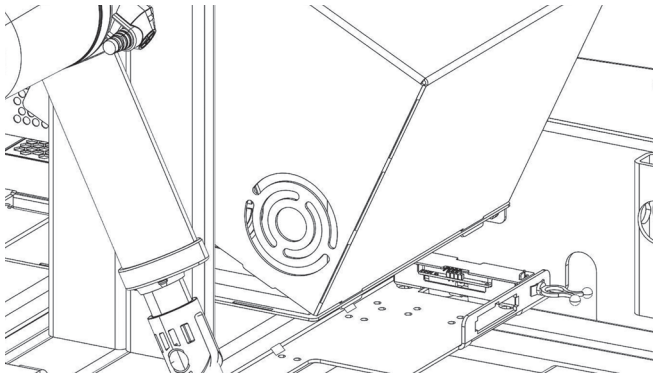

FIGURE: 3

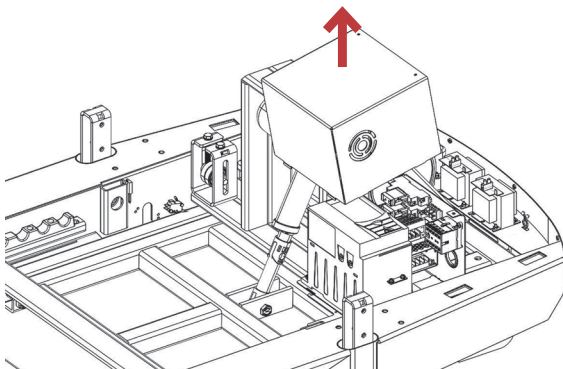

FIGURE: 4

REMOVE INCLINE MOTOR

1. Remove cover, see section "Remove cover"
2. Remove upper M12 screw and lock nut, see fig: 1
3. Remove lower M12 screw and lock nut, see fig: 2
4. Slide out incline motor, see fig: 3

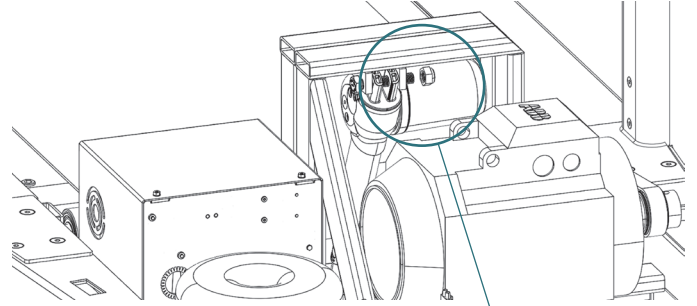

FIGURE 1

1 x M12, screw, lock nut

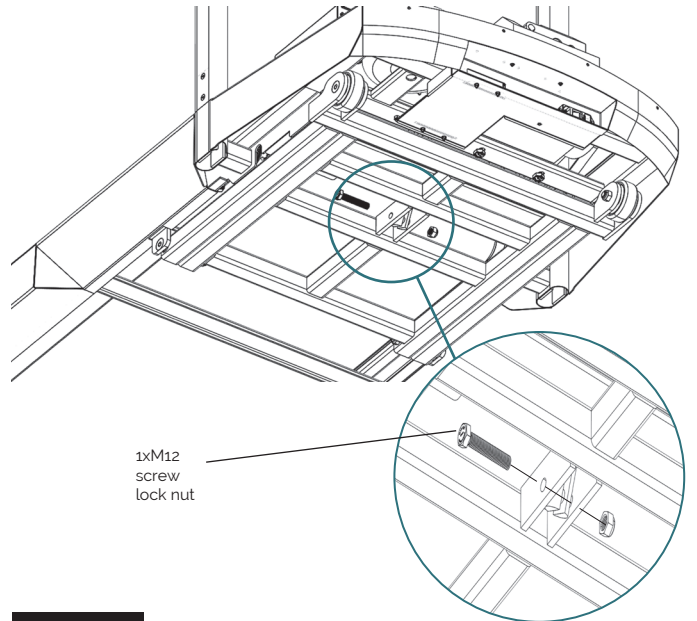

FIGURE 2

1xM12
screw
lock nut

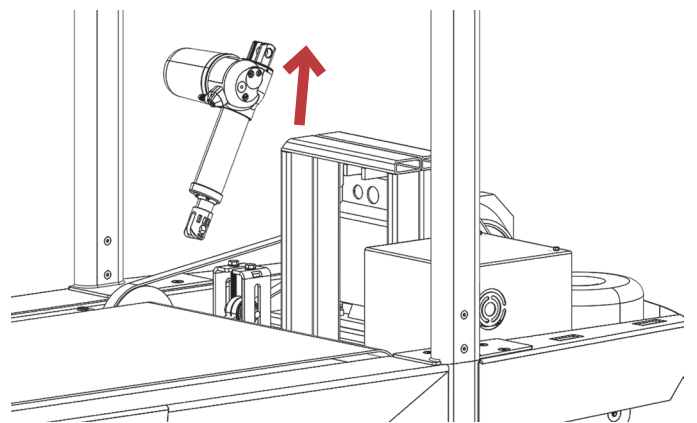

FIGURE 3



REMOVE ROLLERS, BELT AND BOARD

1. Remove cover, see section "Remove cover"
2. Remove handle bars, see section "Remove handle bars"
3. Remove two M10 screws from back rollers, see fig: 1
4. Remove four M10 screws and locknuts from running board, see fig: 2
5. Tilt and remove running board as shown in fig: 3
6. Slide out and remove back roller, see fig: 4
7. Loosen screws for motor belt tensioner, see fig: 5
8. Remove belt from motor belt wheel, see fig: 6
9. Remove M10 screw from front roller, see fig: 7
10. Tilt front roller as shown in picture and slide out, see fig: 8
11. Remove front roller together with running belt and motor belt, see fig: 9

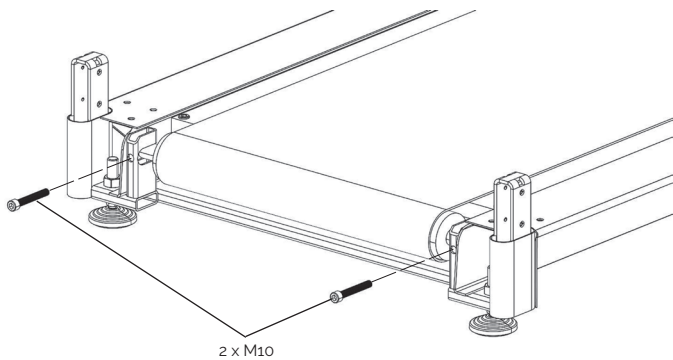

FIGURE 1

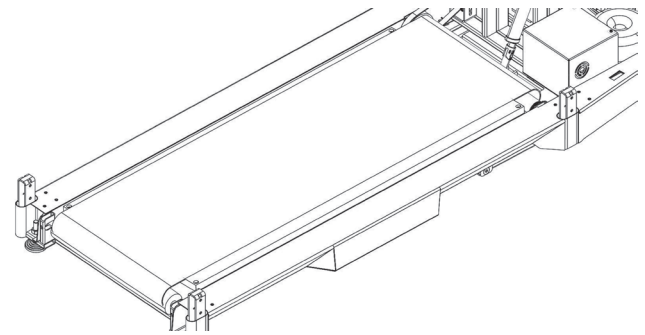

FIGURE 3

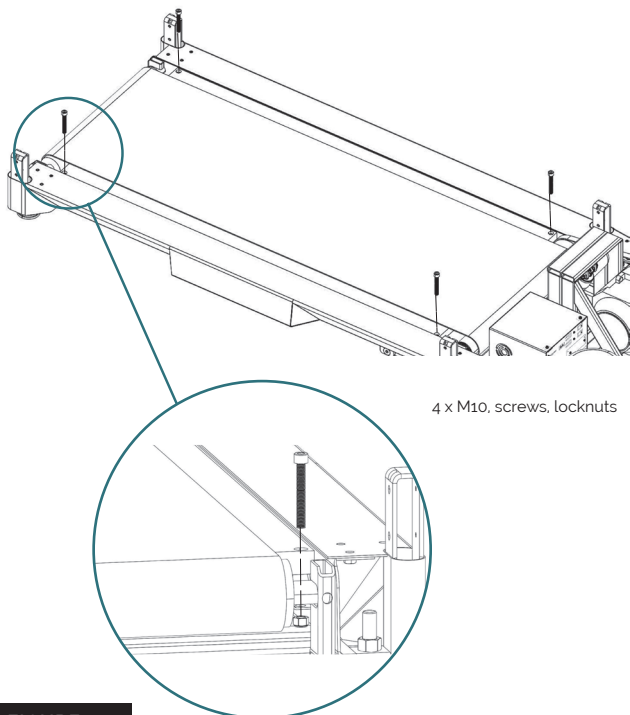

FIGURE 2

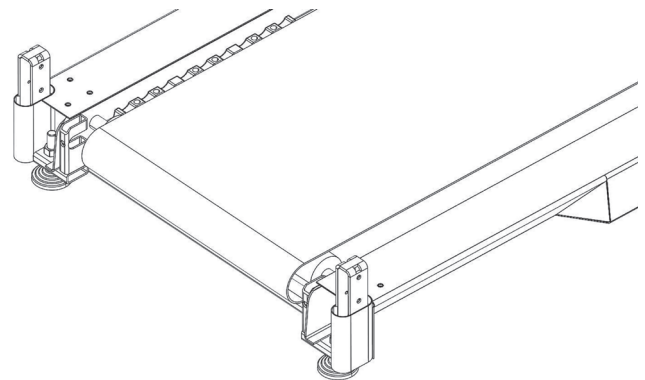

FIGURE 4

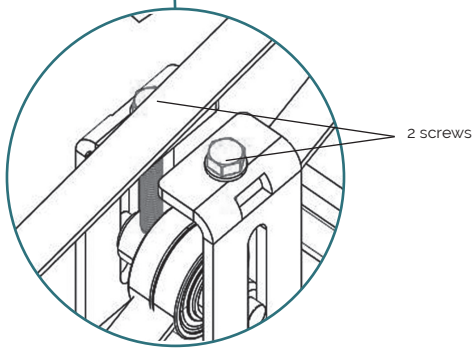
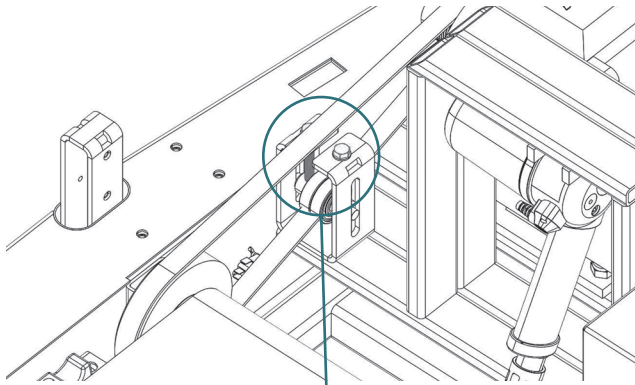

FIGURE 5

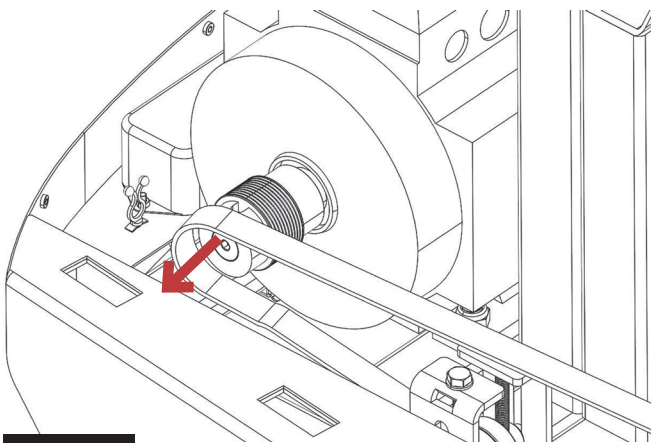

FIGURE 6

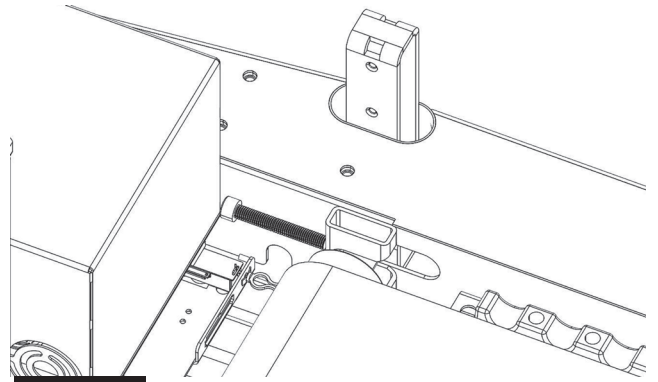

FIGURE 7

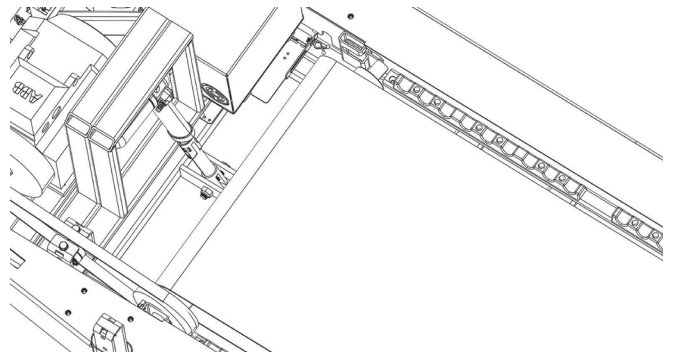

FIGURE 8

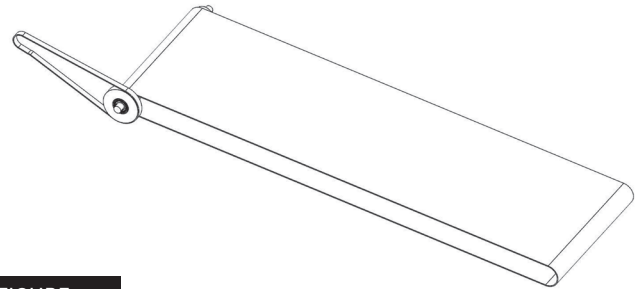

FIGURE 9

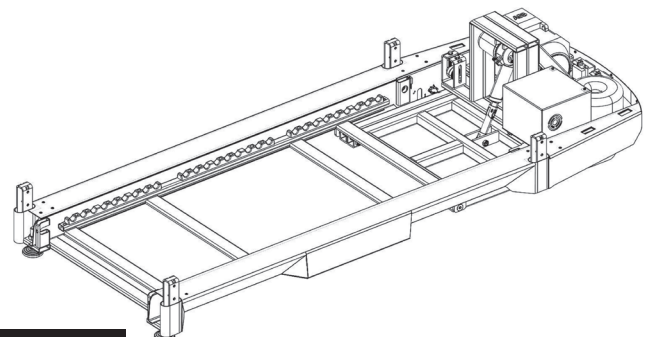

FIGURE 10

REMOVE CASTOR

1. Remove two M12 screws and locknuts, see fig: 1
2. Remove castors, see fig: 2

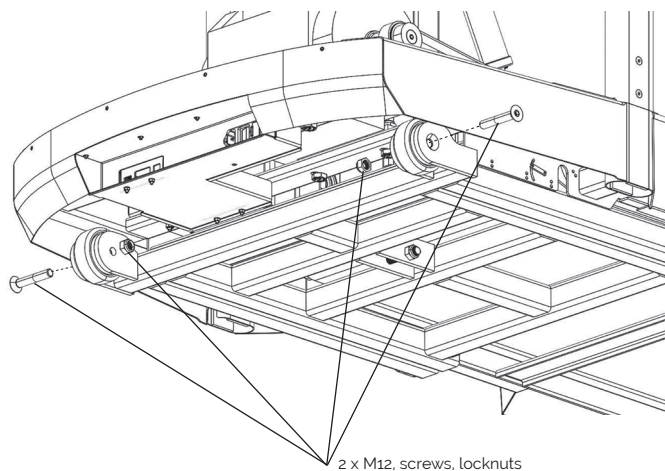

FIGURE 1

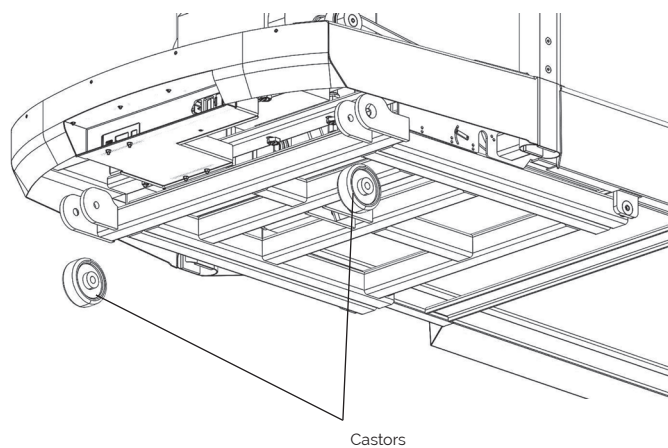
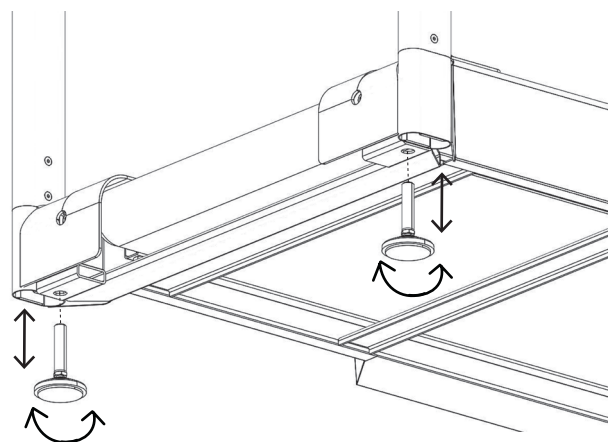

FIGURE 2

ADJUSTABLE REAR SUPPORT FEET



SETTING THE INDUSTRY STANDARD

Despite operating in the ever-changing healthcare field, extensive medical research and top-class Swedish engineering has enabled Monark Exercise's ergometers to remain the industry standard and the world's most widely used—for decades. And they're still recognized as the most accurate in the market.

The unique calibration method, which provides incomparable control and accuracy, makes it easy for clinicians to safely apply the prescribed workload in rehabilitation programs and stress tests, and to make accurate readings. The ergometers can be used with external systems, such as ECG and Spirometri, and are durable and uncompromisingly easy to use—with comfortable low insteps for patients, and intuitive interfaces for test administrators.